

(19) World Intellectual Property Organization
International Bureau



(43) International Publication Date
14 August 2003 (14.08.2003)

PCT

(10) International Publication Number
WO 03/067323 A1

- (51) International Patent Classification⁷: G03B 13/32 // G06T 5/50 (74) Common Representative: AFSENIUS, Sven-Åke; Ugglevägen 12, S-181 56 Lidingö (SE).
- (21) International Application Number: PCT/SE02/01934 (81) Designated States (national): CN, JP, US.
- (22) International Filing Date: 23 October 2002 (23.10.2002) (84) Designated States (regional): European patent (AT, BE, BG, CH, CY, CZ, DE, DK, EE, ES, FI, FR, GB, GR, IE, IT, LU, MC, NL, PT, SE, SK, TR).
- (25) Filing Language: Swedish
- (26) Publication Language: English
- (30) Priority Data: 0200097-4 15 January 2002 (15.01.2002) SE
- (71) Applicant and (72) Inventor: AFSENIUS, Sven-Åke [SE/SE]; Ugglevägen 12, S-181 56 Lidingö (SE).
- Declaration under Rule 4.17:**
— of inventorship (Rule 4.17(iv)) for US only
- Published:**
— with international search report
- For two-letter codes and other abbreviations, refer to the "Guidance Notes on Codes and Abbreviations" appearing at the beginning of each regular issue of the PCT Gazette.*

(54) Title: DIGITAL CAMERA WITH VIEWFINDER DESIGNED FOR IMPROVED DEPTH OF FIELD PHOTOGRAPHING

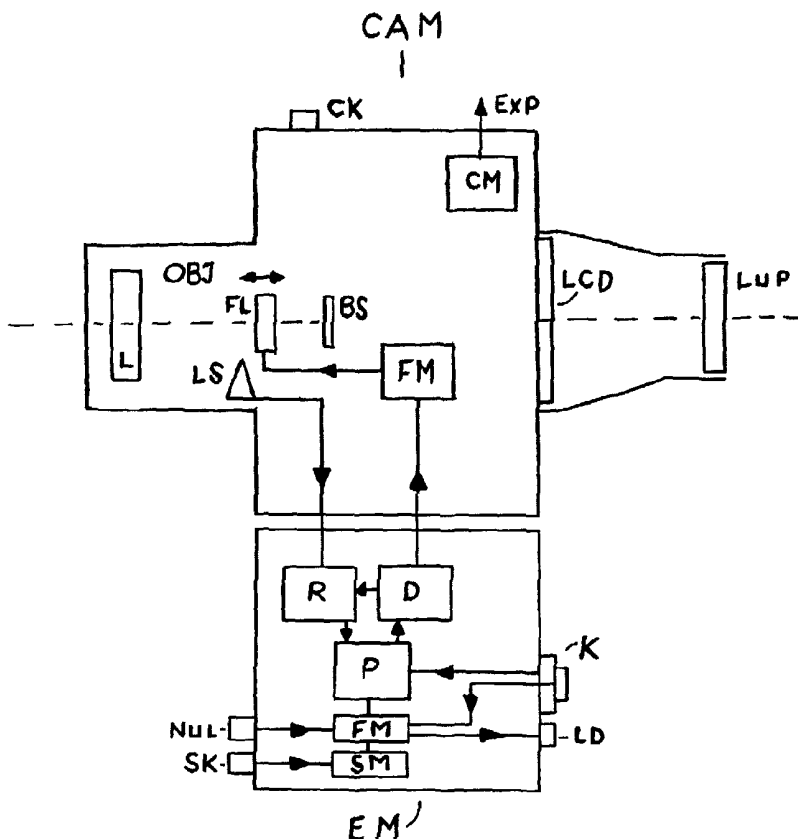

(57) Abstract: The present invention aims at depth of field improvements of digital cameras, where differently-focused images of a scene, to be photographed, are exposed. A final image is produced from these primary-shots, where depth of field-limitations related to classic photo-lenses, are essentially eliminated. Specific new problems related to camera-viewfinders and camera-focusing are emerging however, due to the increasing number of images being registered. Following the present invention, advantageous procedures regarding camera viewfinders, for visualizing the individual primary shots as well as images processed for improved depth of field, are outlined. A simple technique for upgrading a standard digital camera for depth of field-improvement operation, including an adequate method for preselecting focuses, is illustrated by figure 5. These problems and others, related to a photographers adjustments and handling of various kinds of depth of field-enhancing cameras are remedied by applying the present invention.



WO 03/067323 A1